

GMC
TRUCK

V-JIMMY SUBURBAN BONUS/CREW CAB



GMCTRUCK
IT'S NOT JUST A TRUCK ANYMORE.



GMC V-JIMMY

TRUCK Built for the Great Outdoors



Sierra Classic V-Jimmy with Exterior Decor package and other available equipment. Tires are supplied by various manufacturers.

Make tracks for the fun...in style. If going to far-out places is your kind of sport, the full-size V-Jimmy is your kind of truck.

Four-wheel drive gives you the traction you need for off-road going, plus good tracking under various road conditions. And big V8 gasoline and diesel engines pack the power you want for driving in the rough, cruising on the highway, climbing mountain roads or towing trailers.

Inside, V-Jimmy is roomy enough to carry up to five persons — with available rear seat. Or pack aboard up

to 90 cubic feet of gear with the rear seat folded up. As for muscle, the standard GVW rating is a whopping 6100 lb. That's space and load-carrying capacity you just can't get in smaller wagons or compact utility trucks.

WIDER CHOICE OF POWER

Gasoline engine models offer a choice of standard 5.0 Liter V8 power, or — new for '87 — an available 5.7 Liter V8... both with Electronic Fuel Injection. New fast-burn combustion chambers help give both engines higher horsepower and torque ratings for

'87. Diesel models are powered with a truck-tough 6.2 Liter V8 (not available in California). See page 11 for further details.

A TOUGH BREED OF TRUCK

When the going gets tough, V-Jimmy has the equipment to help you handle it. A long list of standard features includes: Rugged carbon steel frame Leaf spring suspension, front and rear Steel-belted, radially ply All Seasons tires Power steering Power brakes And much, much more.

SUBURBAN

Loads of Space for Up to Nine



Sierra Classic Suburban with Exterior Decor package and other available equipment.

The great one for people and payloads. Truck-size roominess with passenger-car luxury. That's GMC Suburban. Equipped with available seating, it can carry up to nine adults, with plenty of room for baggage. And, with the available rear seat removed and the available center seat folded, it provides an 8'4"-long floor with a large 144 cubic feet of cargo space. And it hauls truck-size payloads, too.

Towing trailers. Suburban can handle the big ones with ease. A Series 2500 2-WD Suburban with

available 7.4 Liter V8 gasoline engine, 4.10:1 rear axle ratio and proper trailering equipment can haul a Gross Combination Weight (GCW) of 16,000 lb, including vehicle, passengers, equipment, cargo and trailer. See page 12 for more on trailering.

4-WHEEL DRIVE IF YOU NEED IT Ground-gripping 4-WD Suburbans can be ordered with responsive V8 gasoline or diesel power. And they can be equipped to transport up to nine passengers and their cargo on off-road adventures.

A TRUCKFUL OF STANDARD VALUE

Whichever model you choose, you can count on a full measure of traditional GMC value. From truck-tough frame and suspension to extensive anti-corrosion protection. Standard equipment includes power brakes, power steering (on most models), steel-belted radial-ply tires (All Seasons type on Series 1500 models), and Delco Freedom II batteries. And that's just a sample. Read on for more value features.

BONUS/CREW CAB

Big-Job 4-Door Pickups/Cab & Chassis



4-WD Series 3500 Sierra Classic Wideside Crew Cab shown with available equipment.

Carry a crew of six, plus their gear. GMC Crew Cab models are 4-door Pickups or Cab & Chassis with front and rear bench seats. There's plenty of room and comfort for up to six persons. If you want a big cab without the rear seat, choose the Bonus Cab versions. They offer 55.8 cubic feet of lockable load space behind the front seat. All models have a 164.5" wheelbase, and Pickup models have an 8'-long cargo box.

VERSATILE MOVERS AND HAULERS
Three-quarter and one-ton models

have the muscle it takes to move full loads of passengers and cargo. Properly equipped, they're ideal for towing trailers (or carrying slide-in campers in Pickup applications). And, they're available in gasoline or diesel engine models with 2-wheel drive (R-2500/3500) or 4-wheel drive (V-3500). Dual rear wheels, available for R/V-3500 models, add the capacity for hauling large loads or towing big fifth wheel trailers; these "Heavy Hauler" Pickups have a 10,000-lb GVW rating...up to 11,000 lb for diesel engine Cab & Chassis models.

SPECIAL CHASSIS EQUIPMENT

The available Camper Special Chassis package for Pickups includes a camper body wiring harness and other heavy-duty equipment, depending on model, to permit your Crew Cab or Bonus Cab Pickup to use a slide-in camper body.

There's also an available Commercial Special Chassis equipment package for Pickups that includes the same equipment as the Camper package, with the exception of the camper wiring harness. Ask your GMC Dealer about details of these two packages.

GMC V-JIMMY TRUCK



Sierra Classic interior with bucket seats upholstered in Saddle Tan Custom Cloth trim

Step inside and surround yourself with elegance. V-Jimmy offers two trim levels, both standouts for style.

STANDARD SIERRA TRIM

Here's beauty and luxury not usually associated with standard trim. Foam-cushioned, high-back bucket seats are covered with rich grained vinyl upholstery. Choose from Blue or Saddle Tan. (As an alternative, you can select available Custom Vinyl seat fabric, in which case reclining seat backs, a center console and color-keyed carpeting are included.) Other features include padded instrument panel, padded sunvisors and rear compart-

ment easy entry-exit feature for front passenger seat.

SIERRA CLASSIC AVAILABLE TRIM

This top-level package offers a choice of Blue, Saddle Tan, Burgundy or Slate Gray for the Custom Vinyl or Custom Cloth seat upholstery and coordinated interior trim. Bucket seats with reclining seat backs are included, along with a center console and front floor carpeting. The entire floor is carpeted when the available rear seat is ordered.

Also included are a Deluxe instrument panel with needle-gage instru-

ments, cigarette lighter with ashtray illumination, and front compartment headliner. Doors have full trim panels, padded armrests, map pockets and assist straps. Rear sidewalls are trimmed.

SIERRA CLASSIC EXTERIOR

Outside, the Sierra Classic models sport a Deluxe front end treatment featuring dual headlamps and bright-trimmed grille emblem. Bright moldings embellish the body sides and rear plus wheel openings. Front side marker lamps and taillamps have bright trim.

Two Beautiful Ways to Go



Sierra Classic interior with bucket seats upholstered in Burgundy Custom Cloth trim

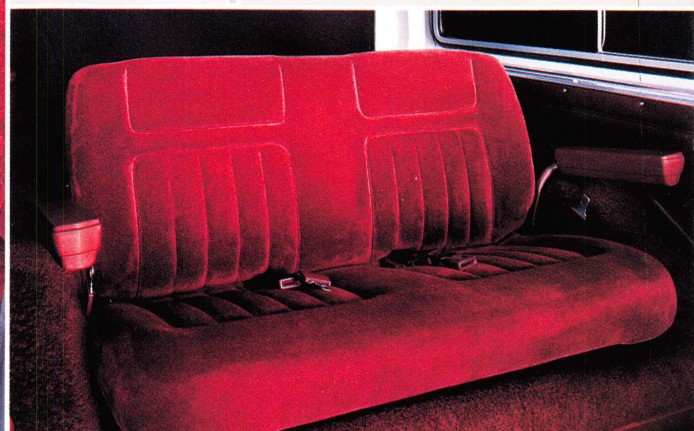

Sierra Classic interior with available 3-passenger folding rear seat and Custom Cloth seat trim

Special steering wheel and instrument panel trim along with needle-gauge instrumentation are included with Sierra Classic trim

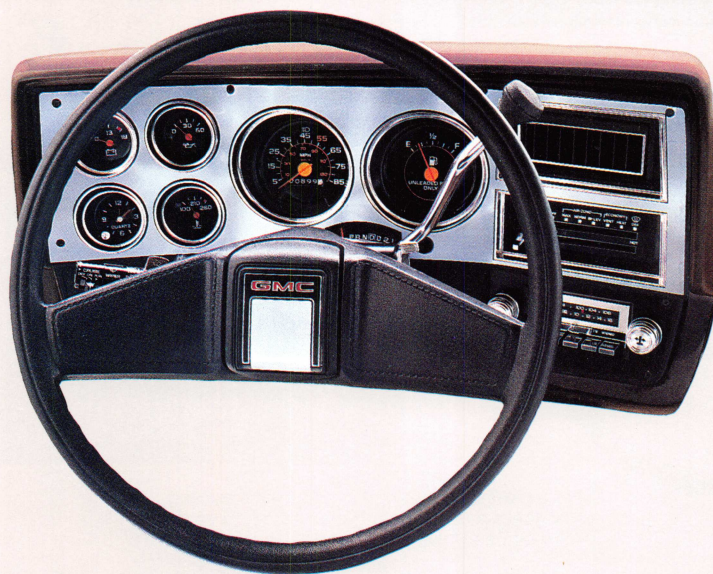

V-JIMMY PAINT SCHEMES

Standard Solid Colors. Choice of eight paint colors (see back cover).

Available Special Two-Tone Scheme. Includes body side and rear moldings, bright wheel opening moldings, and bright side marker and taillamp trim on Sierra models. Secondary color applied below moldings.

Available Exterior Decor Package. Choose from 16 two-tone color combinations. Includes, on Sierra models, moldings and lamp trim in Special Two-Tone scheme plus dual-tone decal striping on body sides and across rear of vehicle. Secondary color applied on body sides and rear between striping and moldings.

Removable Hardtop/Cab Roof Colors. Available in Frost White, Steel Gray, Midnight Black, Midnight Blue, Doeskin Tan, or Indian Bronze depending upon solid or two-tone color selected. In most cases, several choices are available. Consult your GMC Dealer for details.

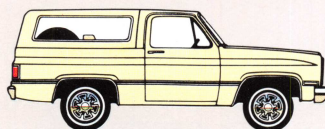

Standard Solid Color Paint

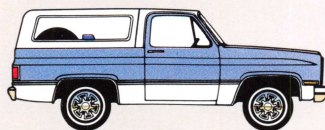

Available Special Two-Tone

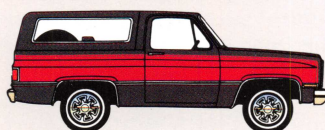

Available Exterior Decor Package

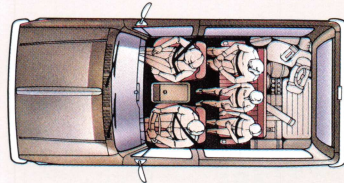

With available 5-person seating, there's 51.5 cubic feet of load space behind the rear seat, or, with the rear seat folded up, 90 cubic feet of load space.

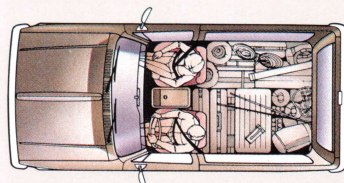

Standard 2-person arrangement allows 106.5 cubic feet of load space.

GMC SUBURBAN TRUCK

High Sierra interior shown with available Custom Vinyl seat trim

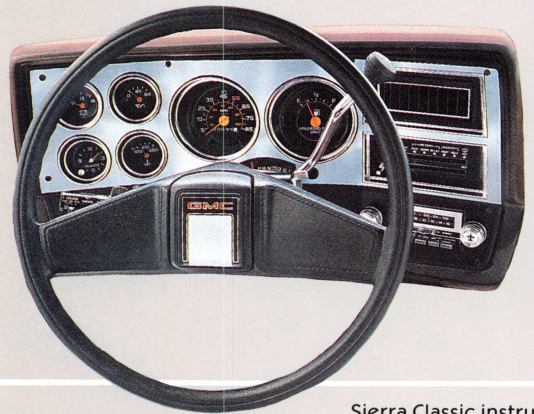

Sierra Classic instrument cluster with needle-type gauges to indicate charging system voltage plus engine temperature and oil pressure



Select one of three interiors. There's handsome standard Sierra trim, plus a choice of two attractive uplevel treatments: High Sierra or Sierra Classic. The comforts begin with the standard 3-passenger front bench seat. Or you can order available reclining front bucket seats on Sierra Classic models. Two available 3-passenger rear seats can increase seating capacity to nine persons.

SIERRA STANDARD TRIM

Sierra presents a sleek, attractive exterior and a very comfortable interior. Deep-foam front bench seat and available rear seats are covered in your choice of Blue or Saddle Stan-

ard Vinyl. Other features include color-keyed dual sunshades; door trim panels with integral armrests; cockpit-type instrument cluster; full-length black rubber floor covering; and all-around tinted windows.

HIGH SIERRA AVAILABLE TRIM

This midlevel trim features a full-length insulated headliner; color-keyed rubber front floor covering (full-length with available rear compartment seating); and front and rear dome lamps with door switches. Seat upholstery is Blue or Saddle Tan Standard Vinyl, or available Custom Vinyl or Custom Cloth. Moldings and bright trim add distinction to the exterior.

SIERRA CLASSIC AVAILABLE TRIM

Suburban's luxury trim reflects beauty, craftsmanship, comfort and convenience. Outside, there are dual headlamps and bright moldings. Inside, there's a Deluxe instrument panel with needle-gage instruments; insulated floor carpeting; Custom steering wheel; and visor mirror. There's a choice of Custom Cloth or Custom Vinyl upholstery for standard or available seating. Interior colors are Blue, Saddle Tan, Burgundy or Slate Gray, depending upon seat and fabric choice. (Details of all trim levels are on back cover.)

Uncommon Room and Luxury



Sierra Classic interior shown with available seating and Custom Cloth seat trim

STANDARD PAINT COLORS
Suburban offers a choice of 10 solid colors. (See back cover.)

AVAILABLE SPECIAL TWO-TONE
Includes bright-trimmed black lower body side and rear moldings (Sierra models), bright front side marker lamp and taillamp trim (Sierra models), and bright wheel opening moldings (Sierra, High Sierra models).

AVAILABLE EXTERIOR DECOR PACKAGE
Includes the moldings and bright trim described above plus upper body side and rear decal stripes coordinated to your choice of 23 two-tone paint combinations.

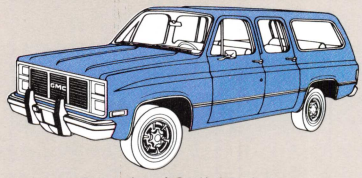

Standard Solid Paint

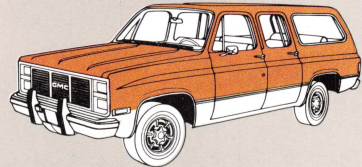

Available Special Two-Tone Paint

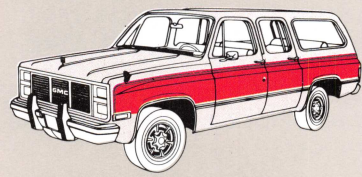

Available Exterior Decor Package

Exterior view of Ducks Unlimited upfitted Suburban*



Interior view of Ducks Unlimited upfitted Suburban*

* Customized vans are supplied to GMC Truck Dealer by outside upfitters, independently of GMC Truck, which is not responsible for the safety or design features, materials or workmanship of any alteration by any such upfitter.

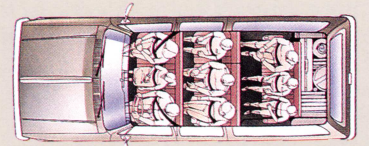

9-person arrangement with standard front bench seat and available center and rear bench seats

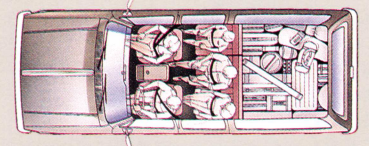

5-person arrangement with available front bucket seats and center bench seat

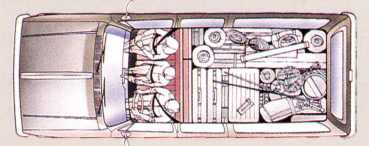

3-person arrangement with standard front bench seat

GMC BONUS/CREW CABS

TRUCK Carry a Full Load or the Whole Crew



Sierra Classic Crew Cab interior with Custom Cloth seat trim

Big on space...and luxury. With 4-door convenience and 6-passenger seating, Crew Cab is well suited to carry a family, or a work crew, to distant places. They'll appreciate the space, the quiet cab, and the comfort of foam-cushioned bench seats. But that's not all. Crew Cab models, and the Bonus Cab versions without rear seat, offer three distinctive trim levels, with three interior color selections for each — Blue, Burgundy or Saddle Tan. The beautiful choice is yours. Bonus/Crew Cabs are available as Wideside Pickup or Cab & Chassis models on both 2- and 4-wheel drive chassis.

AVAILABLE SIERRA CLASSIC

This top-of-the-line treatment offers a choice of Custom Vinyl or Custom Cloth seat upholstery. Underfoot, there's plush wall-to-wall carpeting (front compartment only on Bonus Cabs). Overhead, a cloth-covered insulated headliner. Vinyl door trim panels include distinctive appliques with a brushed pewter-tone finish, color-keyed cloth inserts, and carpet trim.

Convenience touches include a vanity mirror on the right sunshade and

a closing-assist strap and storage pocket on both front doors. Sierra Classic also has a dome lamp, cigarette lighter, illuminated ashtray and door switches for interior lights.

AVAILABLE HIGH SIERRA

At the High Sierra level, there's a choice of Standard Vinyl seat upholstery or available Custom Vinyl or Custom Cloth. A full-length insulated headliner adds to the uplevel good looks. Floor covering is color-keyed rubber (black rubber for Bonus Cab rear floor). Front door switches operate dome and map lights. There's an illuminated ashtray and a cigarette lighter in the instrument panel, plus ashtrays in the rear doors.

STANDARD SIERRA

This handsome interior features deep-foam bench seats (front only on Bonus Cabs) covered in practical, good-looking vinyl. Sierra also provides color-coordinated amenities not usually found in standard models: dual padded armrests; embossed plastic door trim panels; dual padded sunshades; and vinyl-over-foam instrument panel pad. Floor covering is embossed black rubber.



Sierra Classic instrument cluster has brushed pewter-tone trim and full-gage instrumentation

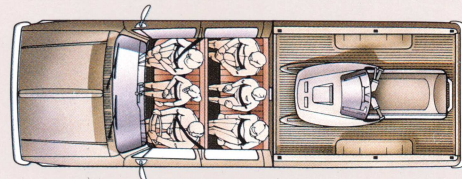

Crew Cab Wideside Pickups have room for six up front plus a spacious 8'-long pickup box for hauling cargo

GMC 4 X 4 TRACTION

TRUCK Leave the Highway Behind



Suburban



Crew Cab Wideside Pickup



V-Jimmy

Shift into 4-WD for work or fun. GMCs with 4-wheel drive deliver the extra traction you need for off-road driving. Plus, sure-footed performance when roads are snow covered. V-Jimmy comes with 4-WD standard. Suburbans and Bonus/Crew Cab models can be ordered as 4-WD models.

MANUAL OR AUTOMATIC HUBS

The standard 4-WD system features dependable manual locking front

hubs that freewheel in 2-WD for highway cruising, but can be locked quickly into 4-WD to traverse low-traction terrain or to engage in such rugged work as snowplowing.

If you encounter few heavy-duty low-traction situations, you may prefer the convenience of available automatic hub locks which permit no-stop shifting into 4-WD at speeds up to 25 mph (V-Jimmy and Suburban only).

AVAILABLE EQUIPMENT

For tackling really rugged work, you may wish to add available equipment such as heavy-duty front springs (except Bonus/Crew Cab models), a Front Quad Shock package (except Bonus/Crew Cab models), a limited-slip rear axle, and stone shields for the fuel tank and transfer case.

POWER For Hauling, Trailering and Traveling

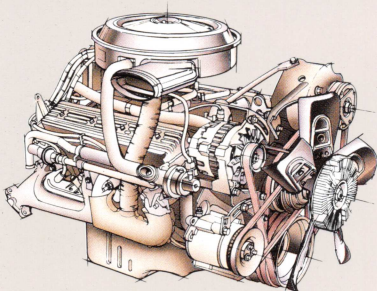

5.0 Liter Fuel Injection V8

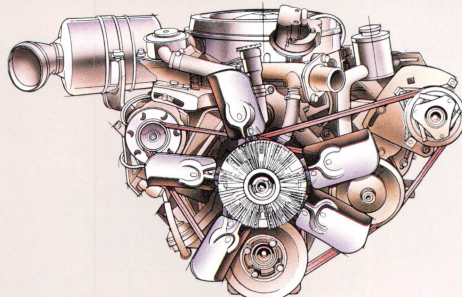

6.2 Liter V8 Diesel

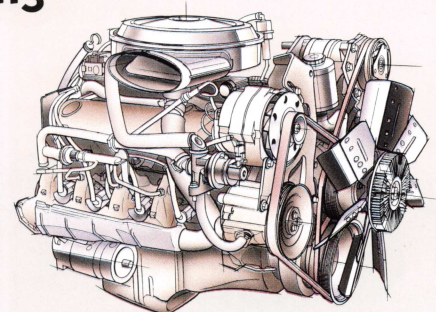

7.4 Liter Fuel Injection V8

New for '87...Computer-Controlled Electronic Fuel Injection. This advanced system is now standard on all gasoline engines for '87 V-Jimmy, Suburban and Bonus/Crew Cab models. It replaces the conventional carburetor and fuel pump and provides a precise fuel-to-air ratio for improved combustion. The result is impressive reliability and performance.

Other Improvements for '87:

All gasoline engines for these models are equipped with new, higher-capacity Delco Freedom batteries and Delcotron generators. The 5.0L and 5.7L gasoline V8s have higher horsepower ratings.

5.0 Liter (305 CID) V8. This engine is improved for '87 with an aluminum, coolant heated intake manifold for efficient fuel flow.

5.7 Liter (350 CID) V8. For '87, this high-performance V8 offers increased compression ratios to produce more power.

7.4 Liter (454 CID) V8. This big V8 is available in all states for 1987. It is a proven performer in heavy load applications, such as trailering.

6.2 Liter (379.4 CID) V8 Diesel. Standard for all diesel models, where available, this truck-tough V8 combines heavy work capability with diesel engine advantages.

New GM-CAMS Maintenance System GM's total computerized diagnostic and repair resources are ready to help with your individual truck gasoline engine problems, should they occur. Ask your participating GMC Dealer for details.

A WORD ABOUT ENGINES:

GMC Trucks are equipped with engines produced at facilities operated by GM car and truck groups, subsidiaries or affiliated companies worldwide.

ENGINE TECHNICAL DATA

DISPLACEMENT/TYPE	GASOLINE			DIESEL	
	5.0L V8	5.7L V8	7.4L V8	LH6 (1) (2)	LL4 (3)
ORDERING CODE	L03	L05	L19	LH6 (1) (2)	LL4 (3)
BORE AND STROKE (in)	3.74 X 3.48	4.0 X 3.48	4.25 X 4.0	3.98 X 3.82	
COMPRESSION RATIO	9.3 to 1	9.3 to 1 (2)	8.6 to 1 (3)	7.9 to 1	
FUEL DELIVERY	Electronic Fuel Injection			Fuel Injection	
SAE NET HORSEPOWER @ RPM	170 @ 4000	210 @ 4000	195 @ 4000 (4)	230 @ 3600	130 @ 3600
SAE NET TORQUE (lb/ft) @ RPM	260 @ 2400	300 @ 2800	300 @ 2800 (4)	385 @ 1600	240 @ 2000
				246 @ 2000	

1 - Not available in California 2 - Models with GVWR's of 8500 lb or below 3 - Models with GVWR's of 8501 lb or over
4 - 185 @ 4000 horsepower and 295 @ 2400 torque for R&V-2500 Suburban in California only and for all Bonus/Crew Cabs

GMC QUALITY OPTIONS

TRUCK

Electronic speed control and intermittent windshield wipers

Comfortilt steering wheel

Front air conditioning

Delco AM/FM stereo radio

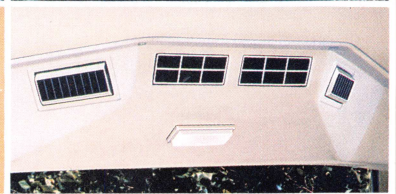
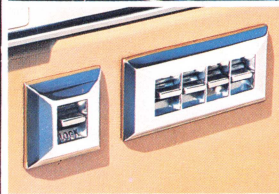
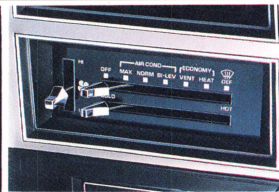
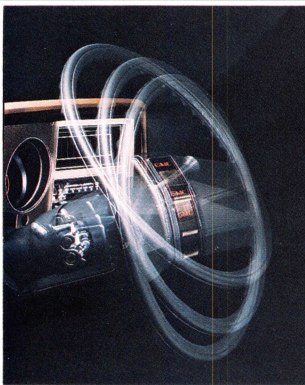
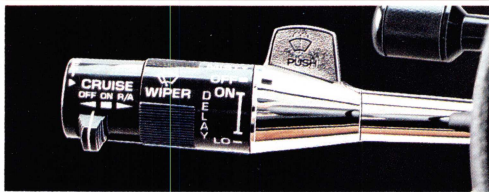

Platform trailer hitch

Power tailgate window control (V-Jimmy and Suburban)

Power door locks and/or power windows

Suburban rear air conditioning (requires front air conditioning)

For added driving pleasure and satisfaction, V-Jimmy, Suburban and Bonus/Crew Cab models offer a variety of popular options. Most of the accessories pictured here are available for all models. You'll find other items listed in the chart on the back cover. Also ask about dealer-installed accessories.

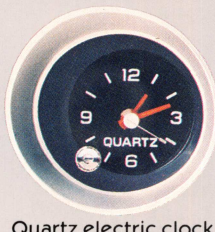

Quartz electric clock



Below eyeline stainless steel mirrors



Rally wheels (V-Jimmy and Suburban)



Aluminum wheels



TRAILERING INFORMATION

GMC full-size Light Duty Trucks are noted for their ability to pull trailers. Properly equipped, a V-Jimmy can move up to 12,000 lb Gross Combination Weight, a Suburban up to 16,000 lb, and a Bonus/Crew Cab up to 19,000 lb — that includes everything going down the road (truck, trailer, passengers, cargo and equipment on truck and trailer). The charts below show the maximum allowable Gross Combination Weight Rating (GCWR) based on all standard and available

engines and rear axle ratios for these models with automatic transmissions.

V-Jimmy and Suburban can be ordered with a heavy-duty Trailering Special Equipment package to help you properly equip your vehicle for trailering. This factory-installed package includes:

- Weight-distributing platform hitch: 9500 lb capacity for Suburban, 6000 lb for V-Jimmy
- 7-lead trailer wiring harness
- Engine oil cooler on gasoline models
- Automatic trans-

mission oil cooler.

For Crew Cab models, there's a dealer-installed weight-distributing platform trailer hitch with a capacity of 7000 lb. Hitches for fifth wheel trailers can be supplied and installed by trailer manufacturers and other sources.

Refer to the '87 GMC Truck Trailering Guide for complete details on requirements for the Trailering Special package plus helpful trailering hints.

GROSS COMBINATION WEIGHT RATING BY ENGINE AND AXLE RATIO FOR AUTOMATIC TRANSMISSIONS

ENGINE	GROSS COMBINATION WEIGHT RATING (lb)				
	9000	9500	10,000	10,500	11,000
	REAR AXLE RATIO				
5.0L V8 GAS (L03)	—	3.08	—	3.42	—
5.7L V8 GAS (L05)	2.73	—	3.08	—	3.42
6.2L V8 DIESEL (LH6/LL4)	3.08	—	3.42	—	3.73

ENGINE	GROSS COMBINATION WEIGHT RATING (lb)				
	12,000	13,500	15,000	16,000	19,000
	REAR AXLE RATIO				
5.7L V8 GAS (L05)	3.73	4.10	—	—	—
7.4L V8 GAS (L19)	—	3.42	3.73	4.10	4.56
6.2L V8 DIESEL (LH6/LL4)	4.10	4.56	—	—	—

TECHNICAL INFORMATION

MODEL NAME	V-JIMMY	SUBURBAN				BONUS/CREW CAB PICKUP AND CAB & CHASSIS			
DRIVE TYPE	4-WHEEL	2-WHEEL		4-WHEEL		2-WHEEL		4-WHEEL	
SERIES	V-1500 (1)	R-1500	R-2500	V-1500	V-2500	R-2500	R-3500	V-3500	
ENGINE	(See Page 11. Consult your GMC Truck Dealer for additional powertrain details.)								
FRONT SUSPENSION	Independent, Coil Springs (2-WD); Salisbury Axle, Leaf Springs (4-WD)								
Capacity (lb)	3600	3250 (2)	3800	3600	3800	3800	4000	4500	
Spring Capacity (lb) (3)	Standard	1650 (4)	1625 (5)	1900	1850	1850	1900	2000	
	Available	2250	—	—	2250	2250	—	—	
Shock Absorber Diameter (mm)	Standard	25	25	32	25	32	32	32	
	Available	32 (6)	32	—	32 (6)	(6)	—	—	
Stabilizer Bar Diameter (in)	Standard	1.25	1.06 (7)	1.06	1.25	1.25	1.06	1.25	
	Available	—	1.06 (8)	1.25	—	—	1.25	1.06/1.25	
REAR SUSPENSION	Salisbury Axle, Leaf Springs								
Axle Capacity (lb)	3750	4000	6000	4000	6000	7500	7500	7500	
Spring Capacity (lb) (3)	Standard	1875	2000	3000	2000	3000	3000	3500	
	Available	—	—	—	—	—	—	3750	
Shock Absorber Diameter (mm)	Standard	25	25	32	25	32	32	32	
	Available	32 (6)	32	—	32 (6)	(6)	—	—	
SERVICE BRAKES	Hydraulic, Front Disc/Rear Drum								
Power Booster Type	Gasoline	Vacuum	Vacuum			Vacuum	Hydraulic		
	Diesel	Hydraulic	Hydraulic			Hydraulic	Hydraulic		
PARKING BRAKES	Cable to Rear Wheels								
STEERING TYPE	Gasoline	Power	Manual (9)	Power			Manual (9)		Power
	Diesel	Power	Power	Power			Power		Power
TIRES	Steel-Belted, Radial-Ply; All Seasons Type on Series 1500 Models								
Standard	P215/75R15	P235/75R15 (10)	LT235/85R16D/E	P215/75R15 (11)	LT235/85R16D/E	LT235/85R16D/E			
	Available	Various (Consult Your GMC Truck Dealer)							
FUEL TANK CAPACITY (nominal gallons)	Standard	25 (12)	25 (12)			20			
	Available	31 (12)	31 and 40 (12)			20 (One Additional Tank)			
BATTERY	12-Volt, Maintenance-Free								
Cold Cranking Amp Rating	Gasoline	Standard: 525; Available: 630 (Required With 7.4L V8 Engine)							
	Diesel	Standard: Dual 540; Available: None							
GENERATOR	12-Volt; Alternating Current								
Amp Rating	Standard	66	66			66			
	With C60 Air	94 (8)	94 (8)			94 (8)			
	With C69 Air	—	78 (7) or 105 (8)			—			
	With C36 Heater or C49 Defogger	—	94 (8)			—			
	With C36 & C49 Together (-C69)	—	78 (7) or 105 (8)			—			

- 1 - Diesel models not available in California
 2 - 3400 lb for diesel models
 3 - At ground, each
 4 - 1850 lb for diesel models
 5 - 1700 lb for diesel models

- 6 - Front Quad Shocks available (four 25 mm front; two 32 mm rear)
 7 - Diesel models only
 8 - Gasoline models only

- 9 - Power available
 10 - XL type on diesel models
 11 - P235/75R15 on diesel models
 12 - Slightly larger for diesel models

IMPORTANT! A WORD ABOUT THIS CATALOG: We have tried to make this catalog as comprehensive and factual as possible and we hope that you find it helpful. However, since the time of printing, some of the information you'll find here may have been updated. Also, some of the equipment shown or described throughout this catalog is available as factory-installed options, as dealer accessories, and as as specialized equipment from various independent suppliers at extra cost. Your dealer has details and, before ordering, you should ask him to bring you up to date.

The right is reserved to make changes at any time, without notice, in prices, colors, materials, equipment, specifications, and models. Check with your GMC Dealer for complete information.

A WORD ABOUT ASSEMBLY, COMPONENTS, AND OPTIONAL EQUIPMENT IN THESE GMC PRODUCTS: The GMC Trucks described in this catalog are assembled at facilities operated by General Motors. These vehicles incorporate thousands of different components produced by car and truck groups and various component divisions of GM and by various suppliers worldwide to General Motors. From time to time during the manufacturing process, it may be necessary, in order to meet public demand for particular vehicles or equipment, or to meet federally mandated emissions, safety, and fuel economy requirements, or for other reasons, to produce GMC products with different

components or differently sourced components than initially scheduled. All such components have been approved for use in GMC products and will provide the quality performance associated with the GMC name.

With respect to extra-cost optional equipment, make certain you specify the type of equipment you desire on your vehicle when ordering it from your dealer. Some options may be unavailable when your truck is built. Your dealer receives advice regarding the current availability of options. You may ask the dealer for this information. GM also requests the dealer to advise you if an option you ordered is unavailable. We suggest that you verify that your truck includes the optional equipment you ordered, or, if there are changes, that they are acceptable to you.

These vehicles also are available under the Chevrolet nameplate (Full-Size Blazer; Series R10, R20, V10, V20 Suburban; Series R20-30 and V30 Bonus/Crew Cab Fleetside Pickup and Chassis-Cab).

A WORD ABOUT UPDATED SERVICE INFORMATION: GMC Truck and Coach Operation regularly sends its dealers useful service bulletins about GMC Truck products. GMC Truck and Coach Operation monitors product performance in the field. We then prepare bulletins for servicing our products better. Now you can get these bulletins, too. Ask your dealer. To get ordering information, call toll free 1-800-551-4123.

STANDARD AND AVAILABLE EQUIPMENT

TRIM LEVEL		SIERRA (STD)	HIGH SIERRA (Z62)(1)	SIERRA CLASSIC (YE9)	
EXTERIOR APPEARANCE					
GRILLE/HEADLAMP BEZELS	Light/Dark Argent Painted Grille with Integral GMC Letters	S	—	—	
	Light/Dark Argent Painted Grille with Bright Applied GMC Letters	A (2)	S	S	
	Light Argent Painted Bezels for Parking Lamps and Single Headlamps	S	S	—	
	Light Argent Painted Bezels for Dual Headlamps (Parking Lamps Behind Grille)	A (2)	A (2)	S	
IDENTIFICATION	Diesel Models	Bright Hood Ornament with "6.2 Litre Diesel" Lettering	S	S	S
		Bright Fender Nameplate with "6.2 Litre Diesel" Lettering	S	S	S
		Bright Tailgate/Rear Door Nameplate with "Diesel 6.2L" Lettering (except Fenderside Pickups)	S	S	S
	Gasoline Models	Bright Tailgate/Rear Door Nameplate with "Fuel Injection" Lettering	S	S	S
		Black Plastic with Bright Trim	A	S	—
		Bright Plastic with Black Trim	A (3)	A	—
ORNAMENTATION	Body Side/Rear Moldings	Custom Black Plastic with Bright Trim	A (3) (4)	A (4)	—
		Deluxe Bright Plastic with Black Trim	A (3) (4)	A (4)	S (4)
		Bright Drip Moldings Over Side Doors and Suburban Rear Doors or Tailgate	S	S	S
		Bright Grille and Headlamp Bezel Outline Moldings	S	S	S
	Bright Front Side Marker Lamp Trim	—	S	S	
	Bright Taillamp Trim (except Fenderside Pickups and Cab & Chassis)	—	S	S	
	Bright Side Rear Clearance Lamp Trim (Dual Rear Wheel Wideside Pickups)	—	S	S	
	Bright Cab Back Panel Moldings (Bonus/Crew Cab Models)	—	—	S	
	Bright Tailgate Applique (except Suburbans)	—	—	S	
	WHEELS/WHEEL TRIM	Bright Metal Hubcaps	S (5)	S (5)	S (5)
		Bright Metal Wheel Trim Covers (R & V-1500 only)	A	A	A
		Bright Metal Wheel Trim Covers (R-3500 only)	A (6)	A (6)	A (6)
Cast Aluminum Wheels (R & V-1500 only)		A	A	A	
Silver Painted Rally Wheels (R & V-1500 only)		A	A	A	
Special Bright Metal Wheel Covers (R & V-2500 and R-3500 only)		A (5)	A (5)	A (5)	
White Painted Conventional Wheels (includes spare on R & V-1500)		S	S	S	
White Painted Styled Wheels (R & V-1500 only, except R-1500 Suburban)		A	A	A	
INTERIOR APPEARANCE					
FLOOR COVERING	Front Compartment	Black Rubber	S (7)	—	—
		Color-Keyed Rubber	—	S	—
		Carpeting	A (8)	—	S
	Rear Compartment	Black Rubber (Jimmy and Bonus Cab)	S	S	S
		Black Rubber (Suburban)	S	S	—
		Black Rubber (Crew Cab)	S	—	—
		Color-Keyed Rubber (Suburban)	—	S (9)	—
		Color-Keyed Rubber (Crew Cab)	—	S	—
		Carpeting (Jimmy)	A (10)	—	A (10)
		Carpeting (Suburban and Crew Cab)	—	—	S
HEADLINER	Front Compartment (Jimmy)	A	—	S	
	Full-Length (Bonus/Crew Cab)	—	S	S	
	Full-Length (Diesel Suburban)	S	S	S	
	Full-Length (Gasoline Suburban)	A	S	S	
INSTRUMENT PANEL TRIM	Instrument Cluster Bezel	Black Crackle Finish and Bright Trim	S	—	—
		Pewter-Tone Brushed Metal Finish and Bright Trim	—	S	S
	Instrument Panel Pad Applique	Black Crackle Finish with Specific Nameplate	S	S	—
STEERING WHEEL TRIM	Black Horn Button with Red GMC Lettering	S	S	—	
	Black Horn Button with Red GMC Lettering and Bright Trim	—	—	S	

S - Standard A - Available
 1 - Except Jimmy models
 2 - Part of available Deluxe Front Appearance package
 3 - Includes bright front side marker lamp trim (all models) and taillamp trim (except Fenderside Pickups and Cab & Chassis)

Exterior Colors



(M) = Metallic
 + Not available on V-Jimmy



Commitment Plus is the most complete joint sales and service customer satisfaction program available on light-duty trucks today. It offers the following benefits:
 — A thorough new-vehicle inspection

TRIM LEVEL		SIERRA (STD)	HIGH SIERRA (Z62)(1)	SIERRA CLASSIC (YE9)		
COMFORT/CONVENIENCE/PROTECTION						
BUMPERS	Chromed Front and Rear without Rub Strips (Jimmy & Suburban)	S	S	S		
	Chromed Front and Rear with Rub Strips (Jimmy & Suburban)	A	A	A		
	Chromed Front (Bonus/Crew Cab)	S	S	S		
	Chromed Rear Conventional (Pickups)	A	A	A		
	Chromed Rear Step-Type (Wideside Pickup)	A	A	A		
	Silver Painted Rear Step-Type (Pickups)	A	A	A		
	FLOOR MATS	Color-Keyed Rubber (with Carpeting)	A	—	A	
		GLASS	Deep-Tinted Glass (Jimmy & Suburban)	A	A	A
			Electric Tailgate Window (Jimmy & Suburban)	A	A	A
			Sliding Rear Window (Bonus/Crew Cab)	A	A	A
Sliding Hardtop Side Window (Jimmy)	A	A	A			
Tinted Glass All-Around (Jimmy & Suburban)	S	S	S			
Tinted Glass All-Around (Bonus/Crew Cab)	A	A	A			
GUARDS	Bright Door Edge	A	A	A		
	Chromed Front Bumper (not available with Rub Strip Front Bumper)	A	A	A		
HEATING/COOLING/DEFOGGING	Air Conditioning, Front	A	A	A		
	Air Conditioning, Front and Rear (Suburban)	A	A	A		
	Cold Climate Package (Gasoline Models)	A	A	A		
	Electric Rear Window Defogger (for E55 Suburban)	A	A	A		
	Flow-Through Power Ventilation	S	S	S		
	Heater/Defogger, Heavy-Duty Outside Air Type (Diesel Models)	A	A	A		
	Heater/Defogger, Outside Air Type	S	S	S		
	Rear Heater (Suburban)	A	A	A		
HORN	Single Electric (Low-Note)	S	S	S		
	Additional Electric (High-Note)	—	S	S		
INSTRUMENT CLUSTER	Gage-Type	A	A	S		
	Quartz-Type Electric Clock (requires gage-type cluster)	A	A	A		
	Warning-Light-Type	S	S	—		
INSTRUMENT PANEL	Central Tip-Out Ashtray	S	S	S		
	Cigarette Lighter with Ashtray Illumination	A	S	S		
	Color-Keyed Energy-Absorbing Pad	S	S	S		
	Right-Hand Storage Compartment with Latch	S	S	S		
	INTERIOR LAMPS	Dome (Bonus/Crew Cab): Single with Door-Operated Switches	A	S	S	
Dome (Jimmy): Front and Rear with Door/Tailgate-Operated Switches		S	—	S		
Dome (Suburban): Front and Rear with Door/Tailgate-Operated Switches (11)		A (12)	S	S		
Map (under instrument panel at center)		S	S	S		
MIRRORS		Dual Chromed Exterior, Conventional Type	S	S	S	
		Dual Painted or Stainless Steel Exterior, Below Eyeline Type	A	A	A	
		Dual Painted Exterior, West Coast Type (Series 3500 Bonus/Crew Cabs)	A	A	A	
POWER DOOR LOCKS/WINDOWS	Dual Stainless Steel Exterior, Camper Type (except Jimmy)	A	A	A		
	Interior Rearview, Prismatic Type	S	S	S		
	Interior Right-Hand Visor	—	—	S		
	Available Separately or Together in Operating Convenience Package	A	A	A		
RADIOS/ANTENNAS	AM, AM/FM, AM/FM Stereo, and AM/FM Stereo with Cassette Tape (Regular or Full-Feature)	A	A	A		
	Windshield Antenna (included with optional radios)	A	A	A		
STEERING WHEEL/COLUMN	Black Energy-Absorbing Column with Anti-Theft Locking	S	S	S		
	Two-Spoke Soft Black Plastic Wheel, Comfortilt Type	A	A	A		
	Two-Spoke Soft Black Plastic Wheel, Conventional Type	S	S	S		
SUNSHADES	Color-Keyed Padded LH/RH	S	S	S		
WINDSHIELD WIPERS/WASHERS	Electric, Two-Speed Wipers; Wet Arm Type Washers	S	S	S		
	Electric, Two-Speed Wipers with Intermittent Wipe Feature; Wet Arm Type Washers	A	A	A		
OTHER EQUIPMENT (See your GMC Dealer for details.)						

4 - Includes bright wheel opening moldings
 5 - Single rear wheel models only
 6 - Dual rear wheel models only
 7 - Color-keyed rubber substituted for diesel engine Bonus/Crew Cab models
 8 - On Jimmy models with available Custom Vinyl seat trim
 9 - With available rear seats
 10 - With available rear seat and front compartment carpeting
 11 - Standard on diesel models
 12 - Part of available interior headliner

NOTE: Due to printing irregularities, colors shown may vary from actual tones. Ask your dealer to show you accurate paint chips and fabric swatches.

- one full tank of fuel
- complimentary 3000-mile maintenance service including oil change and oil filter at no extra charge

GMC Truck and GMC Dealerships are truly committed to making GMC Light Duty Trucks easy to live with. Our customers' total satisfaction is indeed our goal!

Applies to retail sales only, but not to Cab & Chassis models nor any Series 3500 Pickup model described in this catalog.

8981-87 USA
 Litho in USA